



FOCUS **DINE**

English ver.



DINE Inc. Makes a Better
World with its **Technologies
and Quality** in Addition to
Customer Confidence.

By supplying our customers with high-quality products, we contribute to the development of the automobile, electronics, machinery, and plant industries. Furthermore, we make every effort to demonstrate the excellence of Korean cutting tools to the world by exporting our superior-quality cutting tools overseas.

CONTENTS.

▶ DHE	06
▶ DHE/S	07
▶ DHC COLLET	09
▶ MILLING CHUCK	10
▶ C COLLET	12
▶ ER COLLET CHUCK	13
▶ ER COLLET	15
▶ SLA	17
▶ FMA	18

DINE GROUP GLOBAL NETWORKS

- DINE GROUP HEAD OFFICE**
- DINE HEAD OFFICE / DINE FACTORY KOREA**
- KORLOY HEAD OFFICE / KORLOY FACTORY KOREA**
- WIDIN HEAD OFFICE**
- DSP HEAD OFFICE**

- DINE CHINA**
- DINE, KORLOY CHINA FACTORY**

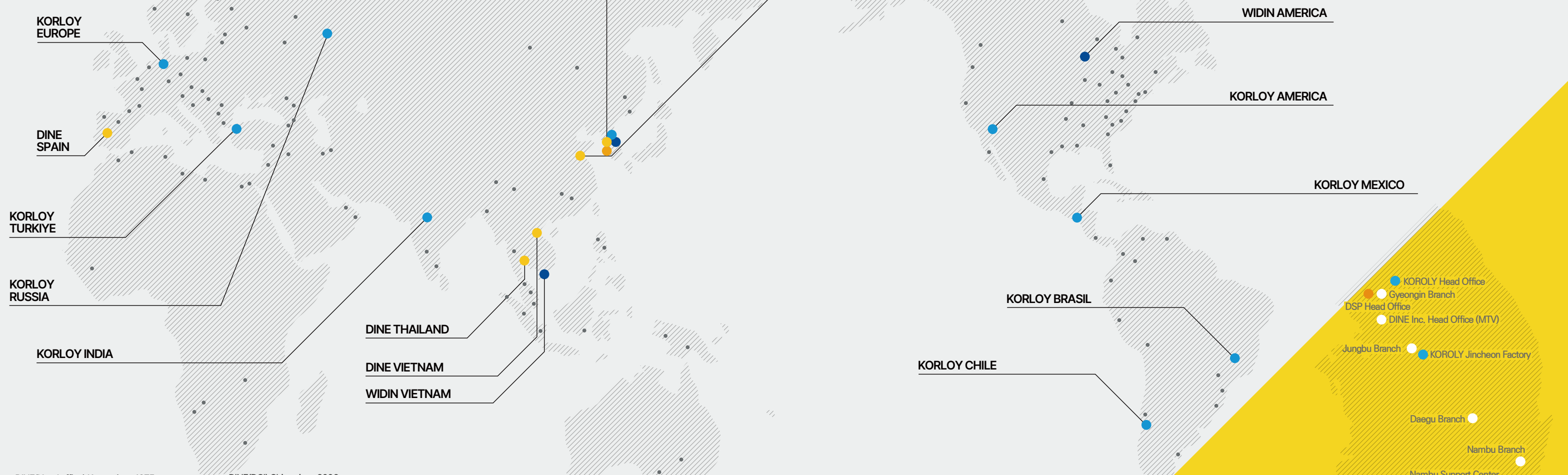

DINE(Head office) Korea since 1975

DINE(DCI) China since 2006



- DINE**
- KORLOY**
- WIDIN**
- DSP**
- Overseas Agents**

DOMESTIC

- KORLOY Head Office**
- Gyeongin Branch**
- DSP Head Office**
- DINE Inc. Head Office (MTV)**
- Jungbu Branch**
- KORLOY Jincheon Factory**
- Daegu Branch**
- Nambu Branch**
- Nambu Support Center SMART FACTORY**
- Changwon Branch**
- WIDIN Head Office**

DINE(DVC) Vietnam since 2017

DINE(DTC) Thailand since 2020

DINE(DMS) Spain since 2022

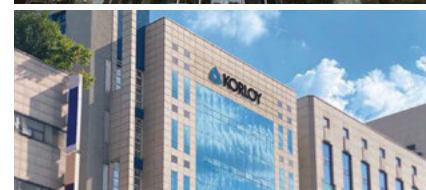

KORLOY Korea since 1966

WIDIN Korea since 1988

DSP Tooling inc. Korea since 2000

Gyeongin Branch



Jungbu Branch



Daegu Branch

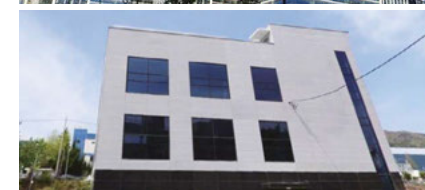

Nambu Branch



Changwon Branch



Nambu Support Center(SMART FACTORY)

Features

- Improved work efficiency by convenient attachment/detachment of tools.
- Improved tool life via high precision.
- Reduced tool shaking during machining by virtue of vibration-resistance effects by hydraulic chamber.

Designation

Designation	CAT 40	DHE	3/4	3.5
	Spindle	Hydraulic Expansion Chuck	Tool Dia	Length

Product Features

Its high precision not only increases the service life of a cutting tool by reducing the wear of the tool but also improves machining surface roughness with the effect of vibration reduction of its hydraulic chamber.

Internal complete sealed structure

- The completely closed system of its inner diameter prevents dust, cutting oil, lubricant, and chips, etc. from penetrating it.
- Maintains clamping force and precision for a long time

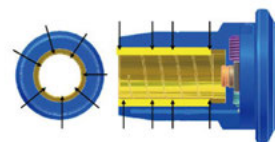

Shank	Grand	Max RPM
CAT50 / HSK100A	G6.3	15,000
CAT40 / BT40 / HSK63A	G6.3	20,000



High Precision

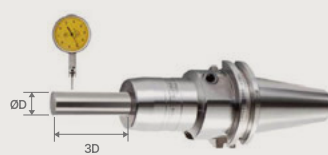

- T.I.R : 5 μ m or below
 - L = 3 x ØD
 - Shank: ØD tolerance:h6

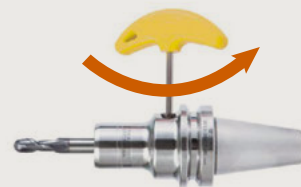

- Convenient tool attachment detachment by T-wrench**

 - Clamping/unclamping structure that only requires simple operation (convenience)
 - : Reduces operator fatigue
 - : Improves equipment operation rate



- Stable Clamping Force**

 - Provides stable clamping force by fixing the space of the holder and the tool with hydraulic pressure

• Provides stable clamping force by fixing the space of the holder and the tool with hydraulic pressure

Features

- Excellent workpiece access due to the slim profile.
- Improved tool life via high precision.
- Reduced tool shaking during machining by virtue of vibration-resistance effects by hydraulic chamber.

Recommended Machining Works

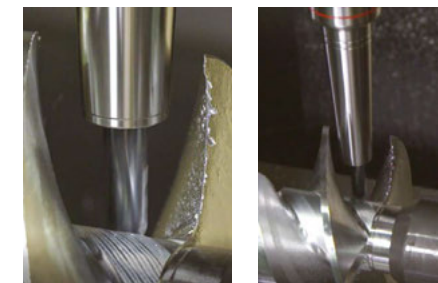

- Optimized for machining that requires high precision
- Enables challenging narrow and deep machining
- Products that require fine boring operations

Products Comparison

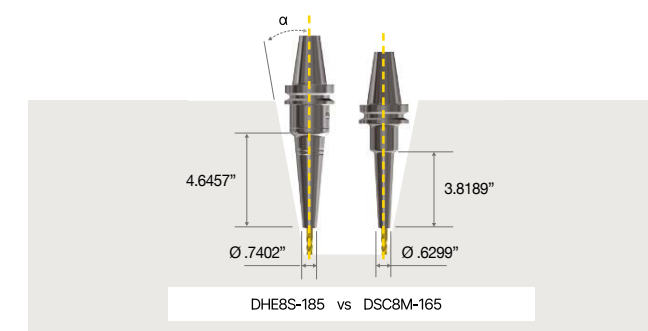

- Length and thickness are the same as those of DSC/M TYPE (if the tool projection length is 1.5748", difference of α = around 2°)
- Longer gauge line and higher rigidity (Compared to the DSC/M Type)
- Ideal for mold machining due to its 3-degree taper shape



Stable Clamping Force

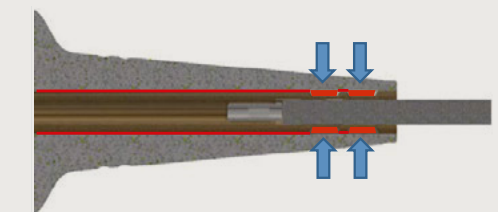

High clamping force and fixing force via 2-point clamping.

High Precision



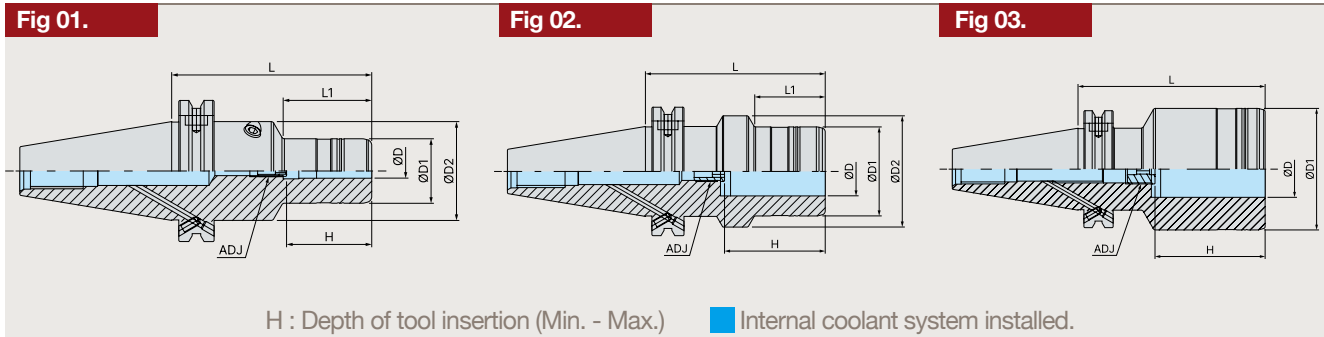

- T.I.R : Under 5 μ m (long type 8 μ m)
- L = 3 x ØD



Designation	ØD	L	ØD1	ØD2	L1	H	ADJ(metric)	RPM	Fig.
CAT40B-DHE1/4-3.50	1/4	3.50	1.14	1.75	1.57	1.57	M5	20,000	1
CAT40B-DHE3/8-3.50	3/8	3.50	1.30	1.75	1.57	1.76	M5	20,000	1
CAT40B-DHE1/2-3.50	1/2	3.50	1.38	1.97	1.34	2.00	M10	20,000	2
CAT40B-DHE1/2-6.00	1/2	6.00	1.38	1.97	1.57	2.00	M10	20,000	2
CAT40B-DHE5/8-3.50	5/8	3.50	1.57	1.75	1.77	2.20	M10	20,000	1
CAT40B-DHE5/8-6.00	5/8	6.00	1.57	1.97	1.77	2.20	M10	20,000	2
CAT40B-DHE3/4-3.50	3/4	3.50	1.73	2.17	1.38	2.31	M10	20,000	2
CAT40B-DHE3/4-6.00	3/4	6.00	1.73	2.17	1.97	2.31	M10	20,000	2
CAT40B-DHE1-4.00	1	4.00	2.60	-	-	2.67	M16	20,000	3
CAT40B-DHE1 1/4-4.00	1 1/4	4.00	2.83	-	-	2.67	M16	20,000	3
CAT50B-DHE1/4-3.50	1/4	3.50	1.14	1.97	1.57	1.57	M5	15,000	1
CAT50B-DHE3/8-3.50	3/8	3.50	1.30	1.97	1.57	1.76	M5	15,000	1
CAT50B-DHE1/2-3.50	1/2	3.50	1.38	1.97	1.57	2.00	M10	15,000	1
CAT50B-DHE1/2-6.00	1/2	6.00	1.38	1.97	1.57	2.00	M10	15,000	1
CAT50B-DHE5/8-3.50	5/8	3.50	1.57	1.97	1.57	2.20	M10	15,000	1
CAT50B-DHE5/8-6.00	5/8	6.00	1.57	2.36	1.77	2.20	M10	15,000	1
CAT50B-DHE3/4-3.50	3/4	3.50	1.73	1.97	1.57	2.31	M10	15,000	1
CAT50B-DHE3/4-6.00	3/4	6.00	1.73	2.36	1.77	2.31	M10	15,000	1
CAT50B-DHE1-3.50	1	3.50	2.60	-	-	2.67	M16	15,000	3
CAT50B-DHE1 1/4-3.50	1 1/4	3.50	2.83	-	-	2.67	M16	15,000	3

Unit : inch

DHE SPARE PARTS Hydraulic expansion chuck parts

Type	Main Components		
	Clamp Bolt	Wrench	
Designation/Image			
CAT 40	BTF1010	DHETW-5	
CAT 50	DHE1/4, 3/8, 1/2, 5/8, 3/4	BTF1010	DHETW-5
	DHE1, 1 1/4	BTF1212-1.5	DHETW-6

Unit : inch

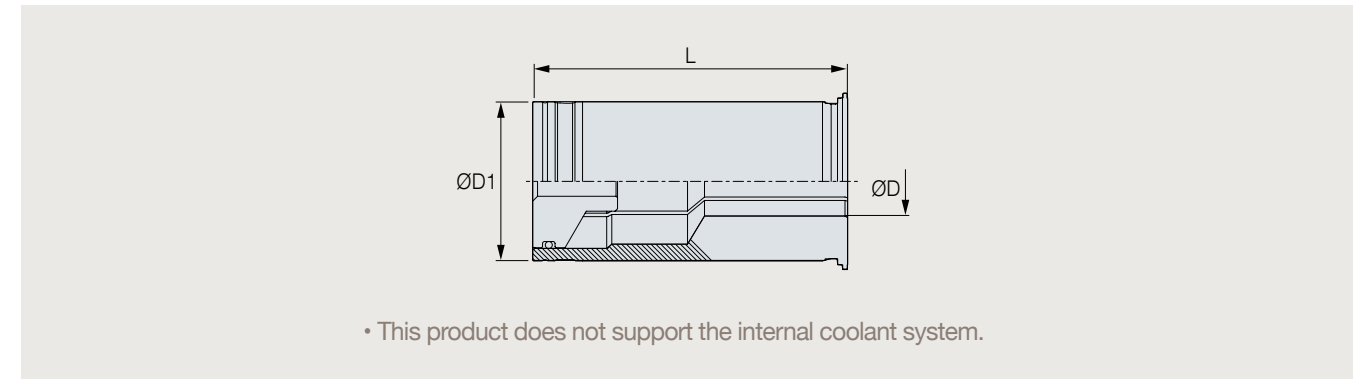

Designation(General-Type)	ØD	L	ØD1
DHC1/2-1/8	1/8	1.85	1/2
DHC1/2-1/4	1/4	1.85	1/2
DHC1/2-3/8	3/8	1.85	1/2
DHC3/4-1/8	1/8	2.05	3/4
DHC3/4-3/16	3/16	2.05	3/4
DHC3/4-1/4	1/4	2.05	3/4
DHC3/4-5/16	5/16	2.05	3/4
DHC3/4-3/8	3/8	2.05	3/4
DHC3/4-1/2	1/2	2.05	3/4
DHC3/4-5/8	5/8	2.05	3/4
DHC1 1/4-1/2	1/2	2.48	1 1/4
DHC1 1/4-3/4	3/4	2.48	1 1/4
DHC1 1/4-1	1	2.48	1 1/4

Milling Chuck

CAT Milling Chuck

ASME
B5.50-CAT

Shank

10 μ m

T.I.R

130~520
kgf.m

Clamping Force

C

Coolant System



Milling



Drilling

Milling Chuck

CAT Milling Chuck

ASME
B5.50-CAT

Shank

10 μ m

T.I.R

130~520
kgf.m

Clamping Force

C

Coolant System



Milling



Drilling

Features

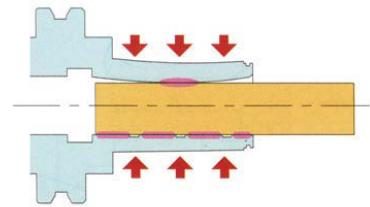

RADIAL GROOVE

- Guarantees even clamping force and minimizes vibration/noise by applying a slot groove in the radial direction.



AXIAL GROOVE

- Axial slot grooves prevent tool slippage by discharging chips during machining.
- Clamping Range : $\varnothing 3/4 \sim \varnothing 1 1/4$

Designation

Designation	CAT 40	C	1 1/4	4.72
	Spindle	Hydraulic Expansion Chuck	Tool Dia	Length

Strong clamping force

X-SLOT system provides strong clamping force from the entrance.

- CAT40B-C1 1/4 : Min. 260kgf·m
- CAT50B-C1 1/4 : Min. 360kgf·m

High precision

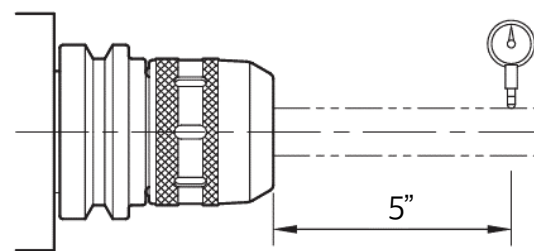

- within 10 μ m at 5" pitch
- T.I.R : Under 10 μ m
- L : 5"

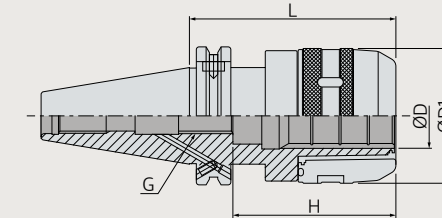

H : Depth of tool insertion ■ : Internal coolant system optional.

Designation	ØD	L	ØD1	H	G	COLLET
CAT40B-C3/4-5.91	3/4	5.90	2.09	2.68	M16*P2.0	C3/4
CAT40B-C3/4-3.35	3/4	3.35	2.09	2.68	M16*P2.0	C3/4
CAT40B-C1-5.91	1	5.90	2.44	2.95	M16*P2.0	C1
CAT40B-C1-3.74	1	3.74	2.44	2.95	M16*P2.0	C1
CAT40B-C1 1/4-4.72	1 1/4	4.72	2.76	3.07	M16*P2.0	C1 1/4
CAT40B-C1 1/4-5.91	1 1/4	5.90	2.76	3.07	M16*P2.0	C1 1/4
CAT50B-C3/4-5.31	3/4	5.31	2.09	2.76	M16*P2.0	C3/4
CAT50B-C3/4-6.50	3/4	6.5	2.09	2.72	M16*P2.0	C3/4
CAT50B-C3/4-3.54	3/4	3.54	2.09	2.72	M16*P2.0	C3/4
CAT50B-C1-5.31	1	5.31	2.44	2.95	M16*P2.0	C1
CAT50B-C1-6.50	1	6.5	2.44	2.95	M16*P2.0	C1
CAT50B-C1-3.54	1	3.54	2.44	2.95	M16*P2.0	C1
CAT50B-C1 1/4-5.31	1 1/4	5.31	2.91	3.74	M16*P2.0	C1 1/4
CAT50B-C1 1/4-6.50	1 1/4	6.5	2.91	3.74	M16*P2.0	C1 1/4
CAT50B-C1 1/4-3.54	1 1/4	3.54	2.76	3.07	M16*P2.0	C1 1/4

Unit : inch

Using O-RING for reduced cutting vibration and increased tool life

High Rigidity Maximize Flexibility

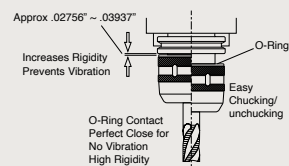

- By applying an O-ring to the nut, cutting vibration is reduced and tool life is increased.
- It also plays an important role in increasing the durability of the milling chuck by preventing the inflow of chips and cutting oil.

Sub-Zero treatment after carburizing



- Remaining austenite of the DINE Milling Chuck is removed through ultra-low temperature treatment below -148°F after carburizing heat treatment.
- This improves hardness and wear resistance and prevents shape deformation.

Accessories

Type	Collet	Spanner
Designation / Image		
C3/4	C3/4	57-60
C1	C1	61-65
C1 1/4	C1 1/4	75-79

ASME B5.50-CAT	Ø13/16" Ø20	C	ER Collet
Shank	Max Dia	Coolant System	ER Collet
Milling	Drilling	Tapping	Chamfering

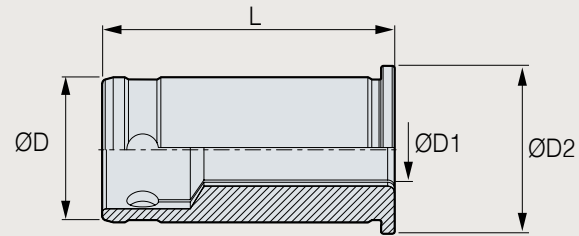

Designation	ØD	L	ØD1(Inch)	ØD2
C3/4-1/4	3/4	2.09	1/4	0.98
C3/4-3/8	3/4	2.09	3/8	0.98
C3/4-1/2	3/4	2.09	1/2	0.98
C3/4-5/16	3/4	2.09	5/16	0.98
C3/4-5/8	3/4	2.09	5/8	0.98
C3/4-7/16	3/4	2.09	7/16	0.98
C1-1/2	1	2.42	1/2	1.14
C1-1/4	1	2.42	1/4	1.14
C1-3/4	1	2.42	3/4	1.14
C1-3/8	1	2.42	3/8	1.14
C1-5/16	1	2.42	5/16	1.14
C1-5/8	1	2.42	5/8	1.14
C1-7/16	1	2.42	7/16	1.14
C1 1/4-1/4	1 1/4	2.54	1/4	1.46
C1 1/4-5/16	1 1/4	2.54	5/16	1.46
C1 1/4-3/8	1 1/4	2.54	3/8	1.46
C1 1/4-7/16	1 1/4	2.54	7/16	1.46
C1 1/4-1/2	1 1/4	2.54	1/2	1.46
C1 1/4-5/8	1 1/4	2.54	5/8	1.46
C1 1/4-3/4	1 1/4	2.54	3/4	1.46
C1 1/4-13/16	1 1/4	2.54	13/16	1.46
C1 1/4-1	1 1/4	2.54	1	1.46

Unit : inch

Designation	ØD	L	ØD1(mm)	ØD2
C3/4-6	3/4	2.09	6	0.98
C3/4-8	3/4	2.09	8	0.98
C3/4-10	3/4	2.09	10	0.98
C3/4-12	3/4	2.09	12	0.98
C3/4-16	3/4	2.09	16	0.98
C1-6	1	2.42	6	1.14
C1-8	1	2.42	8	1.14
C1-10	1	2.42	10	1.14
C1-12	1	2.42	12	1.14
C1-16	1	2.42	16	1.14
C1-20	1	2.42	20	1.14
C1 1/4-6	1 1/4	2.54	6	1.46
C1 1/4-8	1 1/4	2.54	8	1.46
C1.1/4-10	1 1/4	2.54	10	1.46
C1 1/4-12	1 1/4	2.54	12	1.46
C1 1/4-16	1 1/4	2.54	16	1.46
C1 1/4-20	1 1/4	2.54	20	1.46
C1 1/4-25	1 1/4	2.54	25	1.46

Unit : mm

Features

- High efficiency for general machining made possible by reasonable pricing and stable performance.
- Stable run-out when compared to other companies, enabled by the sleeve nuts.
- Covers wide fastening range
- Various machining is available just by replacing the collet.
- Clamping Range : Ø1/16" ~ Ø13/16"
Ø1 ~ Ø20

Designation

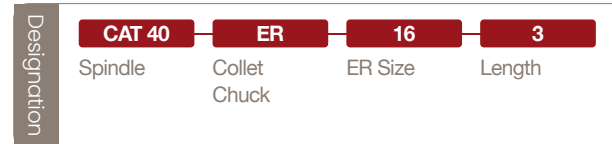

Bearing nuts designed for improved precision



Smooth sleeve bearing nut

Jet coolant disk applicable



After replacing with the general RT/RUT nut, fasten the RTJW
Jet coolant / Inside coolant can be available

ER Collet Chuck

ASME B5.50-CAT Ø13/16" Ø20 C ER Collet

Shank Max Dia Coolant System ER Collet

Milling Drilling Tapping Chamfering

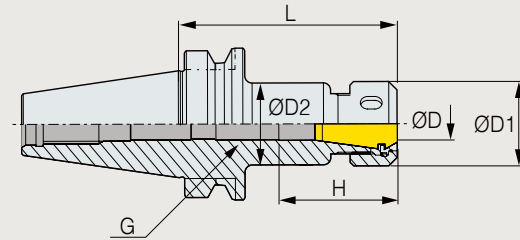

H : Depth of tool insertion Internal coolant system optional.

※ When using the oil hole type , use the standard dimension of collets

Designation	ØD	L	ØD1	ØD2	H	Collet	G
CAT40B-ER11-3.00	0.0625~0.250	3.00	0.71	0.67	1.30	ER11	M7
CAT40B-ER16-3.00	0.0625~0.406	3.00	1.26	1.22	1.77	ER16	M10
CAT40B-ER16-5.00	0.0625~0.406	5.00	1.26	1.22	1.77	ER16	M10
CAT40B-ER20-3.00	0.125~0.500	3.00	1.38	1.34	1.93	ER20	M13
CAT40B-ER20-5.00	0.125~0.500	5.00	1.38	1.34	1.93	ER20	M13
CAT40B-ER25-3.00	0.125~0.625	3.00	1.65	1.61	1.97	ER25	M18
CAT40B-ER25-6.00	0.125~0.625	6.00	1.65	1.61	1.97	ER25	M18
CAT40B-ER32-3.00	0.125~0.8125	3.00	1.97	1.93	2.36	ER32	M22
CAT40B-ER32-6.00	0.125~0.8125	6.00	1.97	1.93	2.36	ER32	M22
CAT50B-ER16-4.00	0.0625~0.406	4.00	1.26	1.22	1.77	ER16	M10
CAT50B-ER16-6.00	0.0625~0.406	6.00	1.26	1.22	1.77	ER16	M10
CAT50B-ER20-4.00	0.125~0.500	4.00	1.38	1.34	1.93	ER20	M13
CAT50B-ER20-6.00	0.125~0.500	6.00	1.38	1.34	1.93	ER20	M13
CAT50B-ER25-4.00	0.125~0.625	4.00	1.65	1.61	1.97	ER25	M18
CAT50B-ER25-6.00	0.125~0.625	6.00	1.65	1.61	1.97	ER25	M18
CAT50B-ER32-4.00	0.125~0.8125	4.00	1.97	1.93	2.36	ER32	M22
CAT50B-ER32-6.00	0.125~0.8125	6.00	1.97	1.93	2.36	ER32	M22

Unit : inch

SPARE PARTS

Type	Main Components		Accessories	
	Nut	Adjust Screw	Spanner	Collet
Designation / Image				
ER11	RN11	BN0716F	20-22	ER11-ØD
ER16	RN16	BN1025F	32-35	ER 16-ØD
ER20	RN20	BN1325F	35-38	ER 20-ØD
ER25	RN25	BN1830F	42-46	ER 25-ØD
ER32	RN32	BN2230F	48-52	ER 32-ØD

ER Collet (INCH)

General 10µm ER Collet

T.I.R

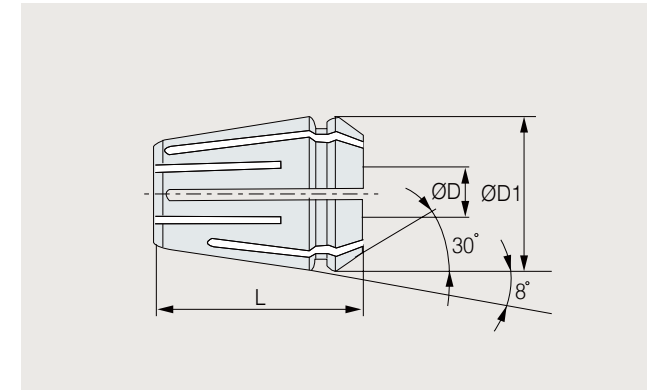

ER collet series	Collet Capacity			
	mm		inch	
	min	max	min	max
ER16	0.5	10.0	0.02	0.41
ER20	0.5	13.0	0.02	0.50
ER25	1.0	16.0	0.04	0.63
ER32	2.0	20.0	0.08	0.81

Designation	ER	ØD	L	ØD1	T.I.R
ER16-1/16	16	1/16	1.083	0.669	10µm
ER16-3/32	16	3/32	1.083	0.669	10µm
ER16-1/8	16	1/8	1.083	0.669	10µm
ER16-5/32	16	5/32	1.083	0.669	10µm
ER16-3/16	16	3/16	1.083	0.669	10µm
ER16-7/32	16	7/32	1.083	0.669	10µm
ER16-1/4	16	1/4	1.083	0.669	10µm
ER16-9/32	16	9/32	1.083	0.669	10µm
ER16-5/16	16	5/16	1.083	0.669	10µm
ER16-11/32	16	11/32	1.083	0.669	10µm
ER16-3/8	16	3/8	1.083	0.669	10µm
ER16-13/32	16	13/32	1.083	0.669	10µm
ER20-1/16	20	1/16	1.240	0.827	10µm
ER20-3/32	20	3/32	1.240	0.827	10µm
ER20-1/8	20	1/8	1.240	0.827	10µm
ER20-5/32	20	5/32	1.240	0.827	10µm
ER20-3/16	20	3/16	1.240	0.827	10µm
ER20-7/32	20	7/32	1.240	0.827	10µm
ER20-1/4	20	1/4	1.240	0.827	10µm
ER20-9/32	20	9/32	1.240	0.827	10µm
ER20-5/16	20	5/16	1.240	0.827	10µm
ER20-11/32	20	11/32	1.240	0.827	10µm
ER20-3/8	20	3/8	1.240	0.827	10µm
ER20-13/32	20	13/32	1.240	0.827	10µm
ER20-7/16	20	7/16	1.240	0.827	10µm
ER20-15/32	20	15/32	1.240	0.827	10µm
ER20-1/2	20	1/2	1.240	0.827	10µm

Designation	ER	ØD	L	ØD1	T.I.R
ER25-1/16	25	1/16	1.339	1.024	10µm
ER25-3/32	25	3/32	1.339	1.024	10µm
ER25-1/8	25	1/8	1.339	1.024	10µm
ER25-5/32	25	5/32	1.339	1.024	10µm
ER25-3/16	25	3/16	1.339	1.024	10µm
ER25-7/32	25	7/32	1.339	1.024	10µm
ER25-1/4	25	1/4	1.339	1.024	10µm
ER25-9/32	25	9/32	1.339	1.024	10µm
ER25-5/16	25	5/16	1.339	1.024	10µm
ER25-11/32	25	11/32	1.339	1.024	10µm
ER25-3/8	25	3/8	1.339	1.024	10µm
ER25-13/32	25	13/32	1.339	1.024	10µm
ER25-7/16	25	7/16	1.339	1.024	10µm
ER25-15/32	25	15/32	1.339	1.024	10µm
ER25-1/2	25	1/2	1.339	1.024	10µm
ER25-17/32	25	17/32	1.339	1.024	10µm
ER25-9/16	25	9/16	1.339	1.024	10µm
ER25-19/32	25	19/32	1.339	1.024	10µm
ER25-5/8	25	5/8	1.339	1.024	10µm
ER32-1/16	32	1/16	1.575	1.299	10µm
ER32-3/32	32	3/32	1.575	1.299	10µm
ER32-1/8	32	1/8	1.575	1.299	10µm
ER32-5/32	32	5/32	1.575	1.299	10µm
ER32-3/16	32	3/16	1.575	1.299	10µm
ER32-7/32	32	7/32	1.575	1.299	10µm
ER32-1/4	32	1/4	1.575	1.299	10µm
ER32-9/32	32	9/32	1.575	1.299	10µm
ER32-5/16	32	5/16	1.575	1.299	10µm
ER32-11/32	32	11/32	1.575	1.299	10µm
ER32-3/8	32	3/8	1.575	1.299	10µm
ER32-13/32	32	13/32	1.575	1.299	10µm
ER32-7/16	32	7/16	1.575	1.299	10µm
ER32-15/32	32	15/32	1.575	1.299	10µm
ER32-1/2	32	1/2	1.575	1.299	10µm
ER32-17/32	32	17/32	1.575	1.299	10µm
ER32-9/16	32	9/16	1.575	1.299	10µm
ER32-19/32	32	19/32	1.575	1.299	10µm
ER32-5/8	32	5/8	1.575	1.299	10µm
ER32-21/32	32	21/32	1.575	1.299	10µm
ER32-11/16	32	11/16	1.575	1.299	10µm
ER32-23/32	32	23/32	1.575	1.299	10µm
ER32-3/4	32	3/4	1.575	1.299	10µm
ER32-25/32	32	25/32	1.575	1.299	10µm
ER32-13/16	32	13/16	1.575	1.299	10µm

Unit : inch

ER Collet (METRIC)

General
10µm
T.I.R



SLA
Side Lock Arbor

ASME
B5.50-CAT
Shank

C
Coolant System

Milling

Drilling

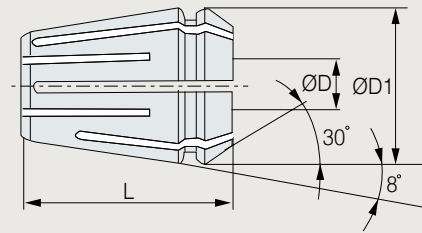

Designation	ER	ØD	L	ØD1	T.I.R
ER11-1.0	11	1.0	18.0	11.5	10µm
ER11-1.5	11	1.5	18.0	11.5	10µm
ER11-2.0	11	2.0	18.0	11.5	10µm
ER11-2.5	11	2.5	18.0	11.5	10µm
ER11-3.0	11	3.0	18.0	11.5	10µm
ER11-3.5	11	3.5	18.0	11.5	10µm
ER11-4.0	11	4.0	18.0	11.5	10µm
ER11-4.5	11	4.5	18.0	11.5	10µm
ER11-5.0	11	5.0	18.0	11.5	10µm
ER11-5.5	11	5.5	18.0	11.5	10µm
ER11-6.0	11	6.0	18.0	11.5	10µm
ER11-6.5	11	6.5	18.0	11.5	10µm
ER11-7.0	11	7.0	18.0	11.5	10µm
ER16-1.0	16	1.0	27.5	17.0	10µm
ER16-2.0	16	2.0	27.5	17.0	10µm
ER16-3.0	16	3.0	27.5	17.0	10µm
ER16-4.0	16	4.0	27.5	17.0	10µm
ER16-5.0	16	5.0	27.5	17.0	10µm
ER16-6.0	16	6.0	27.5	17.0	10µm
ER16-7.0	16	7.0	27.5	17.0	10µm
ER16-8.0	16	8.0	27.5	17.0	10µm
ER16-9.0	16	9.0	27.5	17.0	10µm
ER16-10.0	16	10.0	27.5	17.0	10µm
ER20-1.0	20	1.0	31.5	21.0	10µm
ER20-2.0	20	2.0	31.5	21.0	10µm
ER20-3.0	20	3.0	31.5	21.0	10µm
ER20-4.0	20	4.0	31.5	21.0	10µm
ER20-5.0	20	5.0	31.5	21.0	10µm
ER20-6.0	20	6.0	31.5	21.0	10µm
ER20-7.0	20	7.0	31.5	21.0	10µm
ER20-8.0	20	8.0	31.5	21.0	10µm
ER20-9.0	20	9.0	31.5	21.0	10µm
ER20-10.0	20	10.0	31.5	21.0	10µm
ER20-11.0	20	11.0	31.5	21.0	10µm
ER20-12.0	20	12.0	31.5	21.0	10µm
ER20-13.0	20	13.0	31.5	21.0	10µm

ER collet series	Collet Capacity			
	mm		inch	
	min	max	min	max
ER16	0.5	10.0	0.02	0.41
ER20	0.5	13.0	0.02	0.50
ER25	1.0	16.0	0.04	0.63
ER32	2.0	20.0	0.08	0.81

Designation	ER	ØD	L	ØD1	T.I.R
ER25-2.0	25	2.0	34.0	26.0	10µm
ER25-3.0	25	3.0	34.0	26.0	10µm
ER25-4.0	25	4.0	34.0	26.0	10µm
ER25-5.0	25	5.0	34.0	26.0	10µm
ER25-6.0	25	6.0	34.0	26.0	10µm
ER25-7.0	25	7.0	34.0	26.0	10µm
ER25-8.0	25	8.0	34.0	26.0	10µm
ER25-9.0	25	9.0	34.0	26.0	10µm
ER25-10.0	25	10.0	34.0	26.0	10µm
ER25-11.0	25	11.0	34.0	26.0	10µm
ER25-12.0	25	12.0	34.0	26.0	10µm
ER25-13.0	25	13.0	34.0	26.0	10µm
ER25-14.0	25	14.0	34.0	26.0	10µm
ER25-15.0	25	15.0	34.0	26.0	10µm
ER25-16.0	25	16.0	34.0	26.0	10µm
ER32-2.0	32	2.0	40.0	33.0	10µm
ER32-3.0	32	3.0	40.0	33.0	10µm
ER32-4.0	32	4.0	40.0	33.0	10µm
ER32-5.0	32	5.0	40.0	33.0	10µm
ER32-6.0	32	6.0	40.0	33.0	10µm
ER32-7.0	32	7.0	40.0	33.0	10µm
ER32-8.0	32	8.0	40.0	33.0	10µm
ER32-9.0	32	9.0	40.0	33.0	10µm
ER32-10.0	32	10.0	40.0	33.0	10µm
ER32-11.0	32	11.0	40.0	33.0	10µm
ER32-12.0	32	12.0	40.0	33.0	10µm
ER32-13.0	32	13.0	40.0	33.0	10µm
ER32-14.0	32	14.0	40.0	33.0	10µm
ER32-15.0	32	15.0	40.0	33.0	10µm
ER32-16.0	32	16.0	40.0	33.0	10µm
ER32-17.0	32	17.0	40.0	33.0	10µm
ER32-18.0	32	18.0	40.0	33.0	10µm
ER32-19.0	32	19.0	40.0	33.0	10µm
ER32-20.0	32	20.0	40.0	33.0	10µm

Unit : mm

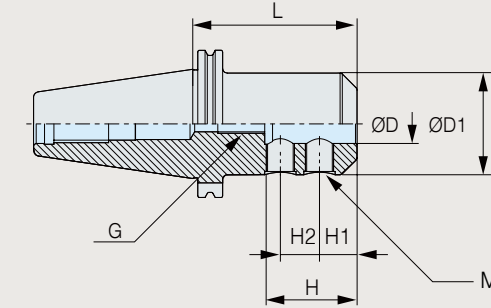

Internal coolant system installed.

Designation	ØD	L	ØD1	H	H1	H2	M	G
CAT40B-SLA1/2-3.50	1/2	3.5	1.65	1.81	0.89	-	7/16"-20UNFx12	M12
CAT40B-SLA5/8-3.50	5/8	3.5	1.89	1.93	0.94	-	7/16"-20UNFx14	M12
CAT40B-SLA3/4-4.00	3/4	4.0	2.05	2.01	0.98	-	5/8"-18UNFx16	M12
CAT40B-SLA1-4.00	1	4.0	2.56	2.32	0.94	0.98	3/4"-16UNFx18	M12
CAT40B-SLA1 1/4-4.00	1 1/4	4.0	2.84	2.48	0.94	1.10	3/4"-16UNFx18	M12
CAT40B-SLA1 1/2-4.00	1 1/2	4.0	3.15	2.87	1.18	1.26	3/4"-16UNFx18	M12
CAT50B-SLA1/2-3.5	1/2	3.5	1.65	1.81	0.89	-	7/16"-20UNFx12	M12
CAT50B-SLA5/8-3.5	5/8	3.5	1.89	1.93	1.65	-	7/16"-20UNFx14	M12
CAT50B-SLA3/4-4.00	3/4	4.0	2.05	2.01	0.98	-	5/8"-18UNFx16	M12
CAT50B-SLA1-4.00	1	4.0	2.56	2.32	0.94	0.98	3/4"-16UNFx18	M12
CAT50B-SLA1 1/4-4.00	1 1/4	4.0	2.84	2.48	0.94	1.10	3/4"-16UNFx18	M12
CAT50B-SLA1 1/2-4.00	1 1/2	4.0	3.15	2.87	1.18	1.26	3/4"-16UNFx18	M12

Unit : inch

Accessories		
Type	Set Screw	Adjust Screw
Designation / Image		
SLA1/2	7/16"-20UNFx12	M1230C
SLA5/8	7/16"-20UNFx14	M1230C
SLA3/4	5/8"-18UNFx16	M1230C
SLA1	3/4"-16UNFx18	M1230C
SLA1 1/4	3/4"-16UNFx18	M1230C
SLA1 1/2	3/4"-16UNFx18	M1230C

Fig 01.

Fig 02.

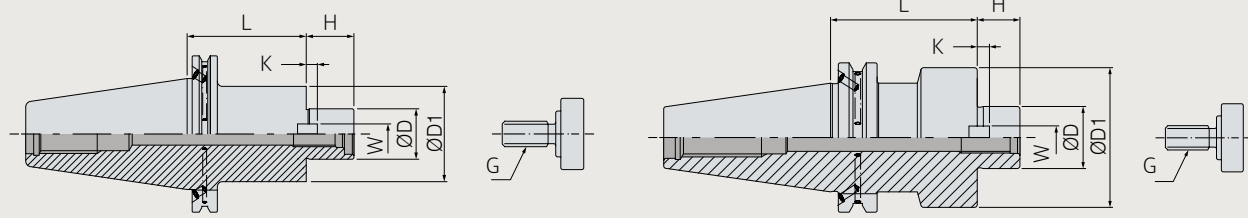

■ Internal coolant system optional.

* The relevant weight excludes the weight of the face cutter.

Designation	ØD	L	ØD1	H	W	K	G	Fig.
CAT40B-FMA1-2.5	1	2.500	2.205	0.669	0.37	0.197	UNF1/2-20	2
CAT40B-FMA1 1/4-2.5	1 1/4	2.500	3.937	0.669	0.50	0.276	UNF5/8-18	2
CAT40B-FMA1 1/2-3.0	1 1/2	3.000	4.921	0.945	0.63	0.354	UNF3/4-16	2
CAT50B-FMA1-2.0	1	2.000	2.205	0.669	0.37	0.197	UNF1/2-20	1
CAT50B-FMA1 1/4-2.5	1 1/4	2.500	3.937	0.669	0.50	0.276	UNF5/8-18	2
CAT50B-FMA1 1/2-2.5	1 1/2	2.500	4.921	0.945	0.63	0.354	UNF3/4-16	2
CAT50B-FMA2-3.0	2	3.000	4.882	1.063	0.75	0.394	UNF1-14	2

Unit : inch

MAIN COMPONENTS
SPARE PARTS

Type	Main Components			
	Key	Key bolt	Mount bolt	Clamp bolt
Designation / Images				
FMA1	K9.5	BX0412	UMF1/2-20	BX1230
FMA1 1/4	K12.7	BX0515	UMF5/8-18	-
FMA1 1/2	K15.87	BX0616	UMF3/4-16	-
FMA2	K19.05	BX0820	UMF1-14	-

ACCESSORIES
SPARE PARTS

Accessories	
Type	Wrench
Designation / Images	
FMA1	LW-10
FMA1 1/4	LW-14
FMA1 1/2	LW-17



 **HEAD OFFICE**

24 (Jeongwang-dong), MTV 26-ro, Siheung-si, Gyeonggi-do, 15118, Korea

Tel. +82-31-488-6200 | Fax. +82-31-432-0583 | Call Center. +82-1544-0920